



model UH100

ULTRASONIC WHOLE ROOM  
HUMIDIFIER OWNER'S GUIDE

READ AND SAVE  
THESE INSTRUCTIONS

[vornado.com](http://vornado.com)

We expect this  
product to be  
perfect.

If it is not, we  
will make it  
right.

vornado.com  
800-234-0604  
help@vornado.com

# CONTENTS

Important Safety Instructions .....	4	Automatic Refill Program.....	12
Getting Started .....	7	Cleaning .....	13
Features .....	8	Storage.....	16
Controls.....	9	Troubleshooting .....	17
Filling Water Tank.....	10	Warranty.....	18
How To Use .....	11		
Mineral Cartridge .....	12		

# READ AND SAVE THESE INSTRUCTIONS

## IMPORTANT SAFETY INSTRUCTIONS

This owner's guide and any additional inserts are considered part of the product. They contain important information about safety, use and disposal. Before using the product, please familiarize yourself with all operating and safety instructions. Please keep all documents for future reference and pass these documents on, together with the product, to any future owner. See our website to view, download and print the most current version of this owner's guide.

**INTENDED USE:** This product is intended to humidify and circulate the air in indoor living spaces only in the United States and Canada. This product is not intended for commercial or industrial use. The manufacturer assumes no responsibility for damage or injury due to unauthorized use or product modification. Failure to follow these directions will void the product warranty.

### **WARNING: Risk to Children and Impaired Persons**

- Supervision is required during the installation, operation, cleaning and maintenance of this product by children age 12 years and younger and anyone with reduced physical, sensory or mental capabilities. Children should be supervised to ensure that they do not play with the appliance, its parts and packaging material.

### **INSTALLATION WARNING—To reduce risk of fire, electrical shock and injury to persons, observe the following:**

- No part of this product (the appliance, power cord, plug, packaging, etc.) should be placed near furnaces, fireplaces, stoves or other high temperature heat sources. Do not use in a window, on an uneven or unstable surface, or near water.

- The appliance, power supply, power cord and plug cannot come into contact with water. Do not use this product on wet surfaces. Do not use this product in a bathtub or shower or position product where it may fall into a bathtub, laundry, swimming pool or other water container. Do not use this product outdoors or expose it to weather or elements.
- Do not run cord under carpeting. Do not cover cord with throw rugs, runners, or similar coverings. Do not route under furniture or appliances. Arrange cord away from traffic area and where it will not be tripped over. The cord should not hang over edges of counters or be placed where it can be crimped or closed in doors. Place appliance near an easily accessible outlet so the product can be unplugged quickly during an emergency.

### **SAFE USE WARNING—To reduce risk of fire, electrical shock and injury to persons, observe the following:**

- **WARNING:** To reduce likelihood of circuit overload, fire and electric shock, do not operate with a solid state speed device, such as a dimmer control switch.
- Do not operate unit if the unit has been dropped or damaged. Do not use this product if it has a damaged power cord or plug. To avoid risk of electrical shock, do not attempt to repair or replace parts. Only original replacement parts may be used. If the power cord is damaged, it must be replaced by the manufacturer, its service agent, or similarly qualified persons in order to avoid a hazard. Contact Vornado Consumer Service at 1-800-234-0604 (phone) or [consumerservice@vornado.com](mailto:consumerservice@vornado.com) (email) for further instructions about replacement and repair.
- Risk of fire. Your appliance may be equipped with a detachable power supply or a cord/plug with a safety device such as a fuse. Use only the power cord and plug provided.

- Before plugging power cord into electrical outlet, be sure that all electrical information on the rating label, including voltage, is compatible with your outlet's power supply.
- Never use the cord as a handle or otherwise yank, strain or stretch the power cord.
- While the product is plugged in, do not insert or allow foreign objects to enter any input or output opening as this may cause risk of electric shock or fire, or damage the product.
- A loose fit between wall outlet (receptacle) and plug may cause overheating and distortion of the plug. Discontinue use of the product in this outlet. Contact a qualified electrician to replace loose or worn outlets.
- This appliance has a polarized plug (one blade is wider than the other.) To reduce the risk of electrical shock, this plug is intended to fit in a polarized outlet only one way. If the plug does not fit fully in the outlet, reverse the plug. If it still does not fit, contact a qualified electrician. Do not attempt to defeat this safety feature.
- The product may be hot when in use. To avoid burns, do not let bare skin touch hot surfaces. Always allow appliance to cool at least 30 minutes before moving, refilling or emptying it. Empty all water and dry unit before storing.
- Before filling with water, moving, repositioning, servicing, cleaning and when not in use, use the product controls to turn off the power and then unplug. To disconnect from outlet, grasp and pull only the plug. Also, power off and unplug if the product will be left unattended for an extended period of time or during electrical storms.
- Electric shock can occur when liquid comes in contact with electricity. Be careful when removing the water tank and refilling to avoid electric shock. Do not pour water through the top Outlet Air Grille on the power head.

- Turn the humidifier off if the relative humidity exceeds 60%. Humidity levels above 60% may allow moisture to build up indoors and condense on surfaces, where microorganisms can settle and grow. For accurate readings, use a hygrometer which is available at most hardware stores and home centers.
- The Mist Outlet and Mist Tube must be used when operating this product. The Mist Outlet and Mist Tube can be removed for cleaning.

**SERVICING WARNING—To reduce risk of fire, electrical shock and injury to persons, observe the following:**

- Clean your product regularly, only as is instructed in this manual. Prior to cleaning, turn off the power on your product and unplug. Do not use gasoline, thinners, solvents, ammonias or other chemicals for cleaning. Refer to the CLEANING instructions provided.
- Do not open appliance housing while product is plugged in. To avoid risk of shock, all service and/or repairs must be done by a Vornado Authorized Service Center.
- Protect against the growth of mold, mildew and other microorganisms by emptying the water tank immediately after each use. If water is left in the tank for longer than 8 hours, thoroughly clean and disinfect the unit as described in the section of this Owner's Guide referenced as "CLEANING".

**DISPOSAL WARNING**

**To reduce waste and environmental harm, observe the following:**



**PACKAGE RECYCLING:** The packaging protects the appliance from transport damage. The packaging materials are selected from the point of view of their environmental

friendliness and disposal technology and are therefore recyclable. Dispose of all packaging materials in an environmentally responsible manner.

**NOTE:** This equipment has been tested and complies with the CFR 47 Part 18 FCC Rules. Operation is subject to the following two conditions: (1) This device may not cause harmful interference, and (2) this device must accept any interference received, including interference that may cause undesired operation.

These limits are designed to provide reasonable protection against harmful interference in a residential installation. This product generates, uses and can radiate radio frequency energy and, if not installed and used in accordance with the instructions, may cause harmful interference to radio communications.

However, there is no guarantee that interference will not occur in a particular installation. If this product does cause harmful interference to radio or television reception, which can be determined by turning the product off and on, the user is encouraged to try to correct the interference by one or more of the following measures:

- Reorient or relocate the receiving antenna.
- Increase the separation between the equipment and receiver.
- Connect the equipment into an outlet on a circuit different from that to which the receiver is connected.
- Contact Vornado Consumer Service or the dealer or an experienced radio/TV technician for help.

This digital apparatus complies with Canadian ICES-001.

Changes or modifications not expressly approved by the party responsible for compliance could void the user's authority to operate the equipment.

## **Supplier's FCC Declaration of Conformity**

Unique Identifier: Vornado Model UH100

Responsible Party: Vornado Air LLC

Mailing Address : 415 E. 13th St., Andover, KS 67002

Contact: [www.vornado.com](http://www.vornado.com)

## **SAVE THESE INSTRUCTIONS**

# GETTING STARTED

Before operating, **ALWAYS** reach under the humidifier and lift from the bottom. Before use, check appliance for visible damage. **DO NOT USE** if there is evidence of damage. If any damage is found, contact Vornado Air, LLC at 1-800-234-0604.



## Check for Leaks

Damage due to shipping may cause leaks in Base or Water Tank. A visual inspection may not reveal hairline fractures.

1. Place humidifier on a water-resistant surface.
2. Fill Water Tank with water to inspect for leaks.
3. Pour several cups of water into Base to inspect for leaks.

## Not Leaking?

Empty water from Base and install full Water Tank.

## Leaking?

In the slight chance your humidifier has leaks, contact Consumer Service and we will immediately replace damaged parts.

A humidifier is quite useful in supplying necessary moisture to dry air. It should be used with proper care to prevent overhumidification.



A good rule of thumb would be to gauge the condensation or frost on windows. Adjust your humidifier to a point where this condition is at a minimum. These adjustments should be made when major changes in outdoor temperatures occur.

Humidifiers can be placed in any living area that has a convenient location and provides distribution of the moist air to the living area. The measured output of a humidifier is based upon continuous operation at standard rating conditions. With normal variations of indoor and outdoor conditions, the humidistat-controlled humidifier will not run continuously at maximum output unless the controls are set to do so.

## INITIAL HUMIDITY REQUIREMENTS:

When initially installed or when placed in operation at the beginning of each season, the humidifier equipped with a humidistat may run constantly for a day or so and, thus, evaporate large quantities of moisture. When the home and its furnishings have absorbed moisture and become stabilized at the desired humidity level, the amount of water used will diminish and the humidifier operation will maintain the desired humidity level.

# FEATURES

## AIR OUTLET GRILLE

Initiates Vornado's signature Vortex circulation. Removable for easy cleaning.

## MIST OUTLET

Moist air is dispersed through the Mist Outlet and projected into Vornado's signature Vortex beam of air - circulating the moist air throughout the entire room.

## MIST TUBE

Guides the mist from inside the humidifier to the mist nozzle.

## POWER HEAD

Powerful motor circulates humidified air throughout whole room.

## BASE

Durable and easy to clean.



## SIMPLETANK™ SYSTEM

This Water Tank is easy to carry, fill, install, clean and view water level. Large 1-gallon capacity.

## INLET GRILLES

Designed for efficient air intake.



## CLEANING BRUSH

Used for cleaning the Base in hard to reach areas. Stored in Base.



## MINERAL CARTRIDGE

Removes minerals from the water, thereby softening the water and reducing harmful mineral buildup on the Transducer.



## CAP & GASKET

Easy-to-remove Cap for convenient Water Tank refilling. The Gasket creates a waterproof seal between Cap and Water Tank.



# CONTROLS



**POWER BUTTON**   
Easily operate with power switch that turns the humidifier On/Off

**OUTPUT**  
Enables you to select the fan speed. Offers **HIGH**, **LOW** or **AUTO** speed selection.

**LED INDICATOR LIGHTS**  
Displays current settings.

**HUMIDITY**  
Control humidity level at 40%–60%, or allow unit to run continuously.

**HUMIDISTAT**  
Reads humidity in room for automatic humidity control.

# FILLING WATER TANK

Before initial use, you must soak the Mineral Cartridge in water for 24 hours. You may use a separate container or Water Tank to do so. If Tank is used, empty water and refill with fresh water prior to use.

**Note:** Spills can occur during cleaning, moving or refilling the Water Tank, so be careful to avoid spills when doing these activities.

1. Unplug humidifier and place on a level surface.

**Note:** The unit may take several minutes to create mist with the initial use of a new Mineral Cartridge.

2. Remove Water Tank from the base by grasping the top integrated handle and pulling up towards you (A). **CAUTION: When removing Water Tank lift vertically, do not twist tank while still in base or Cap may disengage and leak.**
3. Turn the Water Tank upside down and remove the Cap by turning it counterclockwise (B).
4. Gently place Water Tank on a flat surface and fill with cool tap water.
5. Ensure Gasket, the rubber ring around the Water Tank, is properly positioned. Insert the Cap into the grooves of the tank and turn clockwise until tightened. When Cap is fully tightened the arrows on the tank will align with the indicator lines on the Cap (C).
6. Lower Water Tank into Base, positioning Water Tank around the ledge for secure placement (D). Once in nested position, water outlet valve inside Cap opens, releasing water into Base.

**Note:** The rate of water dispensing from Water Tank into Base is controlled by the Mineral Cartridge. The unit may take several minutes to fill the Base.

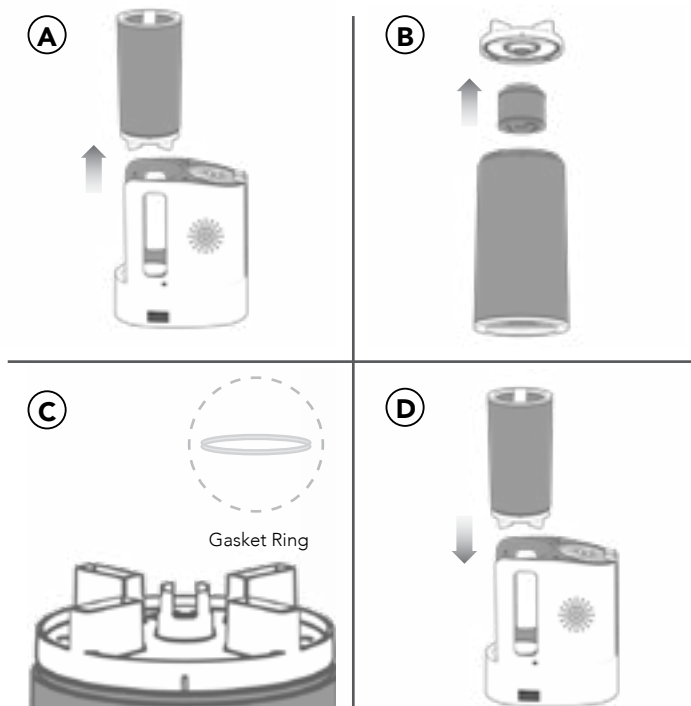

# HOW TO USE

1. Position humidifier to not blow directly on objects or plants. Plug power cord into standard grounded wall outlet. Remove tape from top of mist outlet prior to turning humidifier on.
2. To turn humidifier on, press Power Button. The indicator lights for HIGH fan speed, 50% humidity will illuminate. After first use, humidity setting is saved when powered off. Fan speed will default to HIGH. If unit is unplugged, during next use, settings will default to HIGH fan speed, 50% humidity.

## HIGH

Operation for fast humidification of larger rooms. High-speed operation will evaporate approximately 2 gallons of water in 24 hours of continuous operation. (This assumes room conditions of 70° F and 30% relative humidity.)

## LOW

Operation for quiet, nighttime use or smaller rooms. On Low operation, your humidifier may run without refilling for extended periods.

## AUTO

Operation for more precise humidity control. Fan speed and mist output will fluctuate to better maintain set humidity level with the

3. Use Power Button to select HIGH or LOW fan speed or AUTO mode until the desired setting is illuminated.
4. The humidifier will shut off when it is out of water. Refill with cool water and resume operation.

**Note:** Lower humidity control settings or turn off humidifier if moisture forms on walls or windows.

minimal amount of fan noise. While in Auto, you will only be able to mode through humidity settings (40% - 60%). Continuous will be disabled.

## HUMIDITY – 40%–60% OR CONTINUOUS

Set the humidity level by pressing the HUMIDITY button until the desired humidification level is illuminated. The humidifier will operate until the desired humidity level is reached. At this point, the mist and fan will turn off. If the mist and fan do not turn on, the humidity setting may be lower than the room humidity level. Increase the humidity set point until the mist and fan turn on. This is an indication of the level of humidity already in the room. While in Continuous, you will only be able to mode through High and Low fan speeds before unit powers off. Auto mode will be disabled.

# MINERAL CARTRIDGE

The Mineral Cartridge removes minerals from the water thereby softening the water and reducing harmful mineral buildup on the Transducer.

## WHEN TO REPLACE:

Many factors affect the frequency in which the Cartridge will need to be replaced including amount of use, water hardness, and outside environmental factors. For heavy use, using the unit continuously, we recommend replacing the Cartridge approximately once a month. For lighter use, using the unit intermittently, we recommend replacing the Cartridge every two months.

The Cartridge will need to be replaced earlier if white powder residue accumulates around the device. If the water used in the humidifier has been treated by a decalcification system, the salt from the treatment can show up as white dust also.

## HOW TO REPLACE:

1. Remove Water Tank.  
(See FILLING WATER TANK for instructions)
2. Unscrew Cap.
3. Unscrew Mineral Cartridge from Cap (A).  
Discard Cartridge.

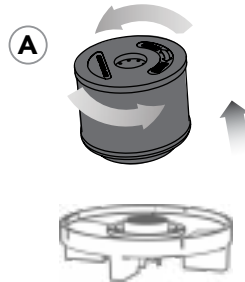

4. Install new Cartridge onto Cap.

**Note:** The unit may take several minutes to create mist with the initial use of a new Mineral Cartridge.

5. If storing unit, empty Water Tank and reinstall Cap. Replace Tank back into unit. See STORAGE.

## AUTOMATIC REFILL PROGRAM

Part # MD1-0018

Select the shipment interval and Vornado will send replacement Mineral Cartridges automatically. Eliminate the hassle of remembering to reorder. Maintain the high efficiency of your Vornado Humidifier. **To sign up**, visit [vornado.com](http://vornado.com), email [consumerservice@vornado.com](mailto:consumerservice@vornado.com) or call 1-800-234-0604. Cancel at anytime.

# CLEANING

Proper cleaning of your Ultrasonic Humidifier is essential to the air quality and performance of your humidifier. The frequency in which your humidifier will need to be cleaned will vary depending on use, water hardness and outside environmental factors. It is recommended, assuming average use, to thoroughly clean the unit several times throughout the season, or when algae, mineral deposits or other particles begin to form. **Note:** If the humidifier is turned Off with water in Base and not turned back on for 8 hours or longer, or if humidifier is not cleaned as recommended, you may experience some growth of algae or bacteria. These microorganisms may become airborne.

## TO CLEAN BASE

1. Turn humidifier Off and unplug.

**Warning: Do not submerge humidifier top in water.**

2. Remove Water Tank by lifting up. To easily remove the Mist Tube, lift main body from base. Then remove the Mist Outlet and Mist Tube by pulling towards you. The Outlet and Tube are two separate parts.

3. Remove the humidifier body from base.

4. Wipe the exterior of the humidifier with a soft, damp cloth if needed.

5. Empty the Base. Clean Base with warm water and a mild detergent.

6. Use brush stored at the bottom of the base for hard to reach areas. Brush can be used to clean out any debris or residue left in the water trough.

7. Rinse and dry. Reassemble humidifier.

8. Prior to use, ensure that the outside of the coupler and surrounding area is completely dry.

**Note:** The Base is not dishwasher safe.

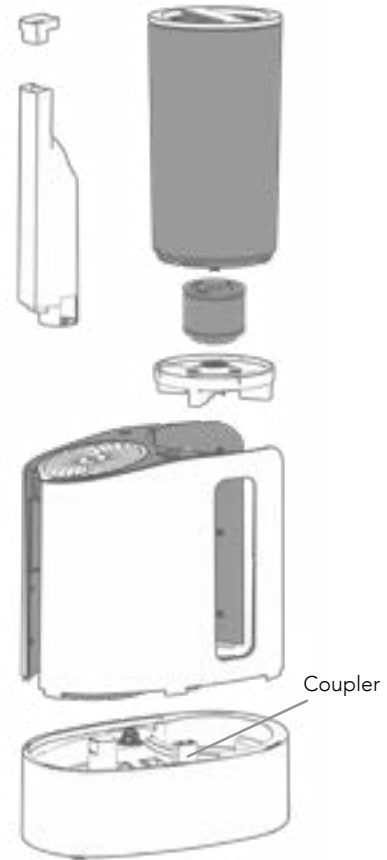

# CLEANING

**Note:** On occasion the Water Tank may need to be wiped down or cleaned to remove build-up of impurities with a mild detergent and cool water. Do not use gasoline, thinners, solvents or other chemicals for cleaning. The Water Tank is not dishwasher safe.

## TO CLEAN GRILLE

1. Turn humidifier Off and unplug.

**Note:** Do not use gasoline, thinners, solvents or other chemicals for cleaning.

2. Remove Mist Outlet. Using a Phillips Head screwdriver, remove screw located at 6 o'clock position inside grille. Twist grille counterclockwise to unlock, then use screwdriver to lift grille.
3. Clean the grille, blade or underside of motor with a soft cloth or with a can of compressed air.
4. Reinstall grille and twist grille clockwise until screw holes align. Replace screw.

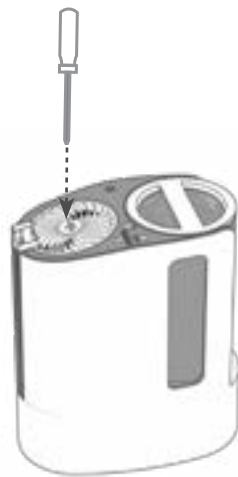

## TO CLEAN MIST OUTLET & MIST TUBE

While you have the humidifier disassembled, if needed, rinse the Mist Outlet and Mist Tube with clean tap water. Be sure the Mist Outlet and Mist Nozzle are removed from the humidifier before cleaning. Ensure both parts are attached before resuming operation.

# CLEANING

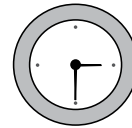
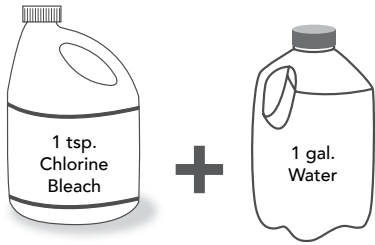

**20 min.**

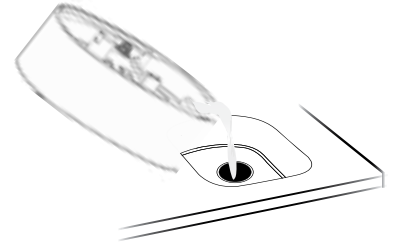

## IN THE EVENT YOU WANT TO DISINFECT THE BASE:

1. Mix solution of 1 teaspoon chlorine bleach and 1 gallon water. Fill Base with solution, wet all surfaces. Let stand 20 minutes, then empty.
2. Rinse Base with water until bleach smell is gone. Dry with clean cloth or paper towel.
3. You may also wipe down the entire surface of humidifier with a soft cloth.

# STORAGE

During the off-season or after extended periods of non-use, you may choose to store your humidifier. To ensure long life of the product, it is recommended to store your humidifier by following these instructions:



Cleaning is recommended before storage.

1. Unplug power cord and bundle loosely.
2. Let humidifier dry completely before storing.  
Do not store with water inside Water Tank or Base.
3. Cover, or place back in retail carton if available.  
This will prevent humidifier from accumulating dust over time.
4. Store humidifier in cool and dry location.

# TIPS

Be aware of several things as your Vornado® Ultrasonic Whole Room Humidifier operates:

- If you operate your humidifier continuously (which is recommended to maintain humidity all day), it may need to be refilled with water every day. Check the Water Tank to be certain that there is an adequate water supply for operation.
- Allow for optimum airflow by keeping the grille unobstructed. Ensure curtains and other items are far enough away from the unit to not be pulled into the side inlets or interfere with airflow.
- Any additives, such as aroma fragrances or water conditioners, must not be used. These additives can cause cracks in the plastic of the humidifier and may affect performance. Any use of such additives voids the manufacturer's warranty.



## DISPOSAL

Dispose of all packaging materials in an environmentally responsible manner.



# TROUBLESHOOTING

## PROBLEM

## POSSIBLE CAUSE AND SOLUTION

Unit fails to power on.

Unit is not plugged in. Plug power cord into electrical outlet.

Household circuit breaker/ground fault circuit interrupter has tripped or blown fuse. Reset circuit breaker/ground fault circuit interrupter, or replace fuse. For assistance, see IMPORTANT INSTRUCTIONS.

Unit is damaged or in need of repair. Cease usage and unplug. Contact Consumer Service for assistance.

Unit makes bubbling or gurgling sound.

This is normal. Water is being dispensed into Base.

Unit is not producing desired amount of humidity or mist output has ceased.

Water level in Tank is empty or too low. Refill with clean, cool tap water. See HOW TO USE.

Unit has reached its set point. When set humidity level is reached, the unit will not produce mist until humidity level in the room drops below humidity set point.

Airflow is blocked. Remove obstruction.

Unit settings are too low. Set to High Output and Continuous Humidity for maximum humidity output.

White dust has accumulated on Mist Outlet or on flooring below.

Mineral Cartridge is no longer removing minerals from water. Cartridge needs to be replaced. See MINERAL CARTRIDGE.

Unit and Transducer is in need of cleaning. See CLEANING.

Water is too hard. Use distilled water.



# WARRANTY

We expect this product to be perfect. If you're not satisfied with this product, let us know.

**We're Here to Help**  
**800.234.0604**  
**vornado.com**  
**help@vornado.com**

Vornado Air LLC ("Vornado") warrants to the original consumer or purchaser this Vornado® Ultrasonic Whole Room Humidifier ("Product") is free from defects in material or workmanship for a period of five (5) years from the date of purchase. If any such defect is discovered within the warranty period, Vornado, at its discretion, will repair or replace the Product at no cost.

For warranty service: Call 1-800-234-0604 or email [help@vornado.com](mailto:help@vornado.com) to obtain a Return Authorization ("RA"). Please have or include your Product's model number and serial number, as well as your name, address, city, state, zip code, e-mail, and phone number when contacting Vornado for warranty service. To file a contactless warranty claim, visit [vornado.com/contact-us](http://vornado.com/contact-us).

After receiving the RA form, ship your Product to: Vornado Air LLC Attn: Warranty & Repair 415 East 13th Street Andover, KS 67002. For your convenience, please have your model number and serial number when contacting Vornado with service inquiries. To assure proper handling, packages must be clearly marked with the RA number. Packages not clearly marked with the RA number may be refused at the receiving dock. Please allow 2-3 weeks for warranty service and return of your Product after the Product is received.

This warranty does not apply to defects resulting from abuse of the Product, modification, alteration, mishandling, improper maintenance, commercial use or repair or service of the Product by anyone other than Vornado; damages which occur in shipment or are attributed to acts of God. Improper product use, which includes using an external device that alters or converts the voltage or frequency of electricity, or shipping a Vornado product to a country not intended for use will void all warranties. Any unauthorized product modification, repair by

unauthorized repair center, or use of non-approved replacement parts is not recommended and any consequences will not be covered by support services or product warranties. The product warranty will be honored only on models that are being used in the country intended. REPAIR OR REPLACEMENT AS PROVIDED UNDER THIS WARRANTY IS THE EXCLUSIVE REMEDY OF THE CONSUMER. VORNADO SHALL NOT BE LIABLE FOR ANY INCIDENTAL OR CONSEQUENTIAL DAMAGES FOR BREACH OF ANY EXPRESS OR IMPLIED WARRANTY ON THIS PRODUCT. EXCEPT TO THE EXTENT PROHIBITED BY APPLICABLE LAW, ANY IMPLIED WARRANTY OF MERCHANTABILITY OR FITNESS FOR A PARTICULAR PURPOSE ON THIS PRODUCT IS LIMITED IN DURATION TO THE DURATION OF THIS WARRANTY. Some states do not allow the exclusion or limitation of incidental or consequential damages, or allow limitations on how long an implied warranty lasts, so the above limitations or exclusions may not apply to you. This warranty gives you specific legal rights, and you may have other rights that vary from state to state. The manufacturer assumes no responsibility for damage caused by failure to follow these instructions or improper product use. Any such actions will invalidate the product warranty.

All company names and product names are trademarks of their respective owners. © All rights reserved. All technical information, data, and instructions for the installation, connection, and operation contained in these instructions for use correspond to the latest available information at time of printing. The contents of this manual may differ slightly from the actual product. Observe any additional supplements.



Designed, engineered and supported in USA.

© 2022 Vornado Air LLC Andover, KS 67002. Patent pending. Specifications subject to change without notice. Vornado® is a trademark owned by Vornado Air LLC.



Vornado Air, LLC  
415 East 13th Street, Andover, Kansas 67002  
800.234.0604 | [vornado.com](http://vornado.com)