

 vornadobaby

# Owner's Handbook

read & save these important instructions



HELLO, I'M  
*Purio*

nursery HEPA air purifier

# Welcome to Vornadobaby

Thank you for choosing to put a Vornadobaby product in your nursery. Our goal is to provide healthy, comfortable air - through every season. Vornado has been doing this for quite a while now. We've brought all our experience in air health and comfort, and tailored it exclusively for your nursery.

---

A THIRD  
generation  
NAME

Vornado



vornadobaby™

Vornado began in 1945, continues to revolutionize airflow today and is now tailored for the nursery.

# Contents

Important Safety Instructions .....	4
Safety.....	7
Purio Controls.....	8
Plug In & Placement.....	9
How To Use.....	11
Purio Filters.....	13
Keeping Purio Clean .....	18
Tips .....	19
Troubleshoot .....	20
Warranty.....	21

# READ AND SAVE THESE INSTRUCTIONS

## IMPORTANT SAFETY INSTRUCTIONS

This owner's guide and any additional inserts are considered part of the product. They contain important information about safety, use and disposal. Before using the product, please familiarize yourself with all operating and safety instructions. Please keep all documents for future reference and pass these documents on, together with the product, to any future owner. See our website [www.vornado.com/air-purifier-manuals](http://www.vornado.com/air-purifier-manuals) to view, download and print the most current version of these instructions.

### **INTENDED USE:**

This product is intended to purify the air in indoor living spaces only in the United States and Canada. This product is intended for floor use only. This product is not intended for commercial or industrial use. The manufacturer assumes no responsibility for damage or injury due to unauthorized use or product modification. Failure to follow these directions will void the product warranty.

### **WARNING: Risk to Children and Impaired Persons**

Supervision is required during the installation, operation, cleaning and maintenance of this product by children

12 years of age and younger and anyone with reduced physical, sensory or mental capabilities. Children should be supervised to ensure that they do not play with the appliance, its parts and packaging material.

### **INSTALLATION WARNING—To reduce risk of fire, electrical shock and injury to persons, observe the following:**

- Place this product away from curtains, draperies, tablecloths and other fabrics, since they may be drawn into the product, damage the motor and/or cause a fire.
- No part of this product (the appliance, power cord, plug, packaging, etc.) should be placed near furnaces, fireplaces, stoves or other high temperature heat sources. Do not use this product in a window, on an uneven or unstable surface, or near water.
- The appliance, power supply, power cord and plug cannot come into contact with water. Do not use this product on wet surfaces. Do not use this product in a bathtub or shower or position product where it may fall into a bathtub, laundry, swimming pool or other water container. Do not use this product outdoors or expose it to weather or elements.
- Do not run cord under carpeting. Do not cover cord with throw rugs, runners, or similar coverings. Do not route cord under furniture or appliances. Arrange cord away from traffic area and where it will not be tripped over. The cord should not hang over edges of counters or be placed where it can be crimped or closed in doors. Place

appliance near an easily accessible outlet so the product can be unplugged quickly during an emergency.

**SAFE USE WARNING–To reduce risk of fire, electrical shock and injury to persons, observe the following:**

- **WARNING:** To reduce likelihood of circuit overload, fire and electric shock, do not operate with a solid state speed device, such as a dimmer control switch.
- Do not operate unit if the unit has been dropped or damaged. Do not use this product if it has a damaged power cord or plug. To avoid risk of electrical shock, do not attempt to repair or replace parts. Only original replacement parts may be used. If the power cord is damaged, it must be replaced by the manufacturer, its service agent, or similarly qualified persons in order to avoid a hazard. Contact Vornado Consumer Service at 1-800-234-0604 (phone) or consumerservice@vornado.com (email) for further instructions about replacement and repair.
- Risk of fire. Use only the power cord and plug provided.
- Before plugging power cord into electrical outlet, be sure that all electrical information on the rating label, including voltage, is compatible with your outlet's power supply.
- Never use the cord as a handle or otherwise yank, strain or stretch the power cord.
- Do not sit or stand on product.
- Do not set anything on product or use as table or shelf.
- Do not use product without filter properly installed.

- While the product is plugged in, do not insert or allow foreign objects to enter any input or output opening as this may cause risk of electric shock or fire, or damage the product.
- A loose fit between wall outlet (receptacle) and plug may cause overheating and distortion of the plug. Discontinue use of the product in this outlet. Contact a qualified electrician to replace loose or worn outlets.
- This appliance has a polarized plug (one blade is wider than the other.) To reduce the risk of electric shock, this plug is intended to fit in a polarized outlet only one way. If the plug does not fit fully in the outlet, reverse the plug. If it still does not fit, contact a qualified electrician. Do not attempt to defeat this safety feature.
- Before moving, repositioning, servicing, cleaning and when not in use, use the product controls to turn off the power and then unplug. To disconnect from outlet, grasp and pull only the plug. Also, power off and unplug if the product will be left unattended for an extended period of time or during electrical storms.

**SERVICING WARNING–To reduce risk of fire, electrical shock and injury to persons, observe the following:**

- Clean your product regularly, only as is instructed in this manual. Prior to cleaning, turn off the power on your product and unplug. Do not use gasoline, thinners, solvents, ammonias or other chemicals for cleaning. Refer to the CLEANING instructions provided.

- Do not open appliance housing while product is plugged in. To avoid risk of shock, all service and/or repairs must be done by a Vornado Authorized Service Center.

### **FCC Compliance Statement**

This device complies with Part 15 of the FCC Rules. Operation is subject to the following two conditions: (1) This device may not cause harmful interference, and (2) this device must accept any interference received, including interference that may cause undesired operation.

**NOTE:** This equipment has been tested and found to comply with the limits for a Class B digital device, pursuant to Part 15 of the FCC Rules. These limits are designed to provide reasonable protection against harmful interference in a residential installation. This equipment generates, uses and can radiate radio frequency energy and, if not installed and used in accordance with the instructions, may cause harmful interference to radio communications. However, there is no guarantee that interference will not occur in a particular installation. If this equipment does cause harmful interference to radio or television reception, which can be determined by turning the equipment off and on, the user is encouraged to try to correct the interference by one or more of the following measures:

- Reorient or relocate the receiving antenna.
- Increase the separation between the equipment and receiver.

- Connect the equipment into an outlet on a circuit different from that to which the receiver is connected.
- Contact Vornado Customer Service or dealer or an experienced radio/TV technician for help.

This Class B digital apparatus complies with Canadian ICES-003.

Changes or modifications not expressly approved by the party responsible for compliance could void the user's authority to operate the equipment.

### **Supplier's FCC Declaration of Conformity**

Unique Identifier: Vornado Model PURIO

Responsible Party: Vornado Air LLC

Mailing Address : 415 E. 13th St., Andover, KS 67002

Contact: [www.vornado.com](http://www.vornado.com)

# **SAVE THESE INSTRUCTIONS**

# Safety

**Plug It In Safely!** Your Purio has a 6 ft. power cord, covered for additional safety. Vornado recommends placing product as close to an outlet as possible and securing the remaining cord.



## Locking Controls

Keeps Purio Off when not in use.



## No Pinch Points or Sharp Edges

Worry free protection in the baby room.



## Finger Friendly Design

Resists curious fingers.



## Sturdy Base

Maintains upright position.



## Door Lock

Secured Door Lock protects baby from any moving parts and dirty filters.



## Covered Power Cord Storage

Safely store power cord inside base of Purio.

# Purio Controls



- ① Power (⏻)
- ② Sleepy Time (🌙)
- ③ Fan (🌀 - ●●● High, ●● Medium, ● Low)
- ④ Filter Reset Buttons
- ⑤ Control Lock (🔒)
- ⑥ Night Glow (💡)
- ⑦ Filter Cover Lock (🔒)



# Plug In & Placement

## Power Cord Storage

For your convenience and safety the Power Cord Storage keeps the power cord neat and out of harm's way.

1. Lift the Power Cord Storage flap to locate plug, then unwind the power cord stored inside.

**Safety Tip:** Power cords increase strangulation risks. Secure as much excess cord as possible inside the Power Cord Storage.

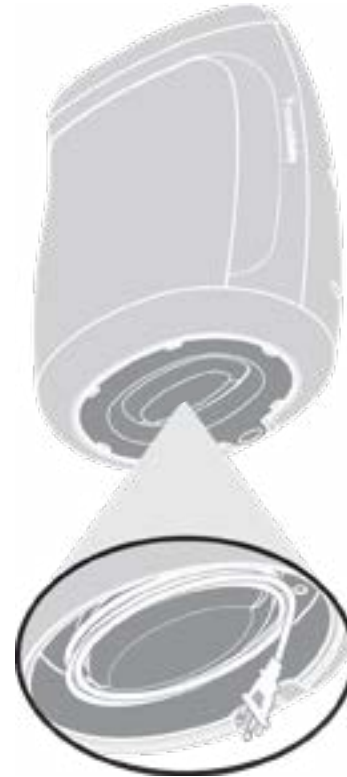

## Set Up

1. Position Purio so the air is directed across the room, unobstructed.
2. Plug power cord into standard wall outlet.

**Safety Tip:** It is best to position Purio close to the power outlet and store excess power cord inside the Power Cord Storage.



# How To Use

## Operation

1. Press Power button On (⏻). The control panel will illuminate when On and dim after approximately 20 seconds.



2. Press the Night Glow button (💡) to power Night Glow On or Off.



3. Press the Fan button (🌀) to select desired Fan speed. Low speed (●), Medium speed (●●) or High speed (●●●).



4. Select the Sleepy Time button (🌙) if desired. This feature will automatically adjust the Fan speed to Low and power the Night Glow Off when Purio senses no light or low light conditions.

**Note:** Previous control settings are kept for the next time Purio is powered On, unless Purio is unplugged.

## Locking Controls

1. To engage this feature press and hold the Control Lock button (🔒) for 3 seconds. The Control Lock icon will blink 3 times rapidly to show it is locked.



**Note:** The Control Lock icon will blink 3 times slowly if any button is pressed while the Control Lock is engaged. While this feature is engaged you will not be able to change the settings or Power Purio On or Off. If Purio is powered Off, you may still engage the Control Lock.

2. To turn this feature off press and hold the Control Lock button (🔒) for 3 seconds.

# Purio Filters

While your Purio came equipped with Filters, you will eventually have to replace the Activated Carbon Filter after 4,000 hours and HEPA Filter after 9,000 hours of run time, depending on use. Replace the Filters with only genuine Vornado® brand Filters. Purio will ping to notify when the Activated Carbon Filter and HEPA Filter should be replaced. If powered On, the Night Glow will slowly fade On and Off.

## Replacing the Filters

The word HEPA or Carbon will illuminate on Purio when it is time to replace the Filter.

1. Power Purio Off and unplug.
2. Push Panel Unlock button to release the front panel. Pull the front panel away from Purio.

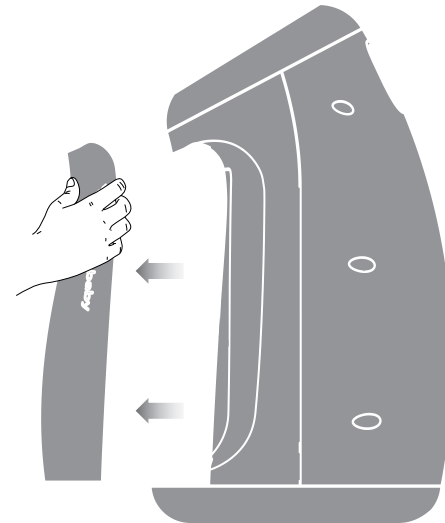
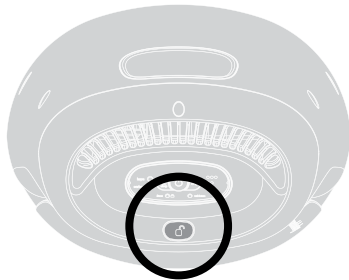

# Purio Filters

3. Remove the Permanent Pre-Filter by pulling on the center. You may need to flex the Permanent Pre-Filter slightly to release the tabs at the sides.

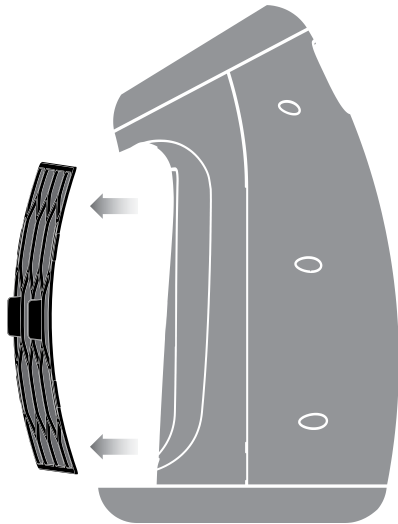

4. Take hold of the Activated Carbon Filter at any place along the perimeter and remove.

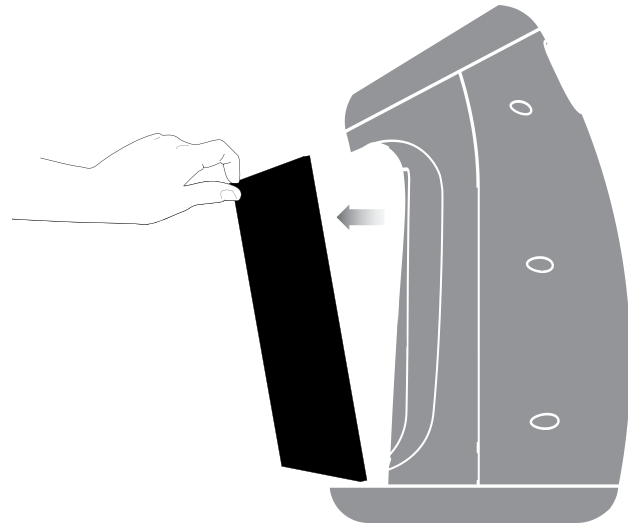

**5.** To remove the HEPA Filter, take hold of the tab and pull to release.

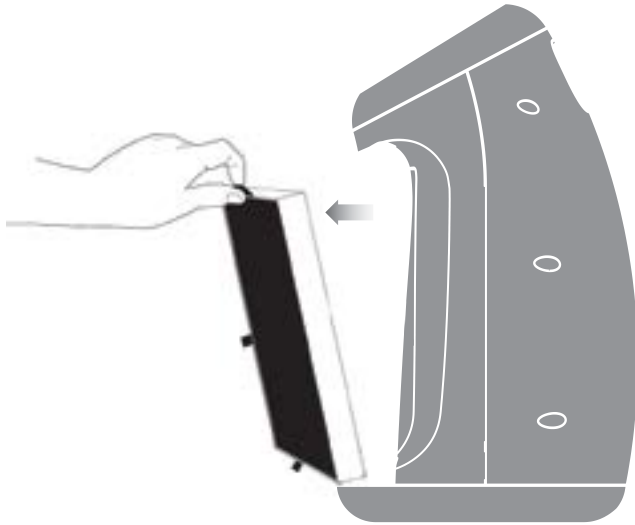

**6.** Remove and discard used Filters. Replace with genuine Vornado Filters.

**7.** Gently press around the perimeter of the Filter to ensure secure placement.

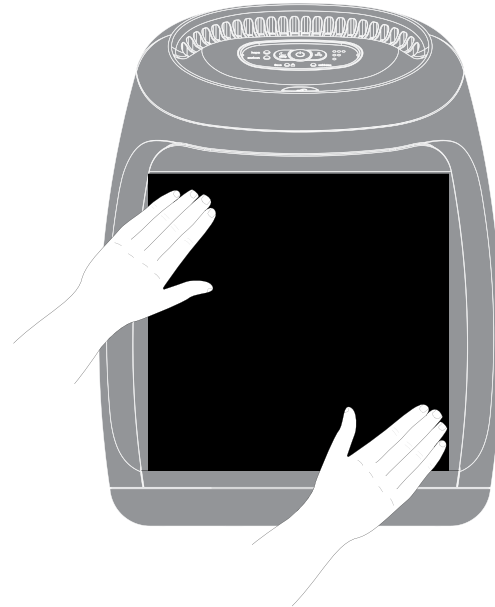

# Purio Filters

8. To replace Permanent Pre-Filter you may need to flex the Permanent Pre-Filter slightly to insert the tabs at the sides.

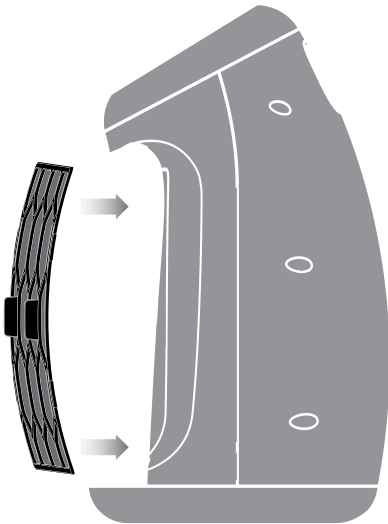

9. Replace Front Panel. Align the tabs at the bottom and push the Front Door closed until you will hear the lock engage. Purio will not power On if the Front Panel is not securely in place.

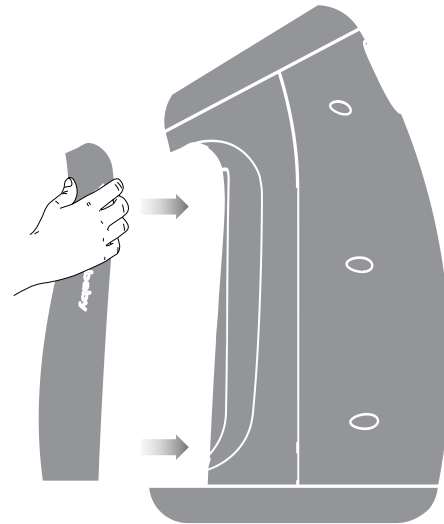



10. To reset Filter notification, press and hold the Carbon or HEPA reset button for 3 seconds or until Carbon or HEPA is no longer illuminated.



### Automatic Refill Program

Select the shipment interval and Vornado will send replacement Filters automatically. Eliminate the hassle of remembering to reorder. Maintain the high efficiency of your Vornado Purio. To sign up, visit [www.vornadobaby.com](http://www.vornadobaby.com), email [consumerservice@vornado.com](mailto:consumerservice@vornado.com) or call 1-800-234-0604. Cancel at anytime.



Model # MD1-0031



Model # MD1-0030

# Keeping Purio Clean

## Cleaning

1. Power Purio Off and unplug.
2. Dust or vacuum the Grill and Air Inlets.



**Note:** Do not use gasoline, thinners, solvents or other chemicals for cleaning.

3. The Permanent Pre-Filter can be cleaned with a vacuum or rinsed.

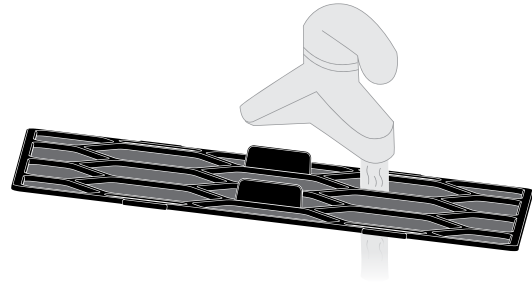

**Note:** If vacuuming, use the vacuum brush attachment. If rinsing, allow Permanent Pre-Filter to completely dry.

# Tips

- During the off-season or after extended periods of non-use, you may choose to store your Purio. To ensure long life of the product, it is recommended to store your Purio by following these instructions:
  - Unplug power cord and wrap cord neatly inside the Safe Storage.
  - Thoroughly clean your Purio.
  - Use the brush attachment on your household vacuum cleaner to vacuum any accumulated dust on Purio or wipe down the entire surface with a soft cloth. You may also use a can of compressed air for debris.
  - Cover, or place Purio back into retail carton if available. This will prevent Purio from accumulating dust over time.
  - Store Purio in a cool and dry location.
- Always set Power button to Off and unplug Purio before cleaning.
- The motor is permanently lubricated and requires no oiling. Do not use gasoline, thinners, solvents or other chemicals for cleaning.
- Your Purio has no user serviceable parts. Do not disassemble Purio. This will void your warranty. If service is required, return your Purio to Vornado (see WARRANTY for instructions).

# Troubleshoot

<b>Unit fails to power on.</b>	Unit is not plugged in. Plug power cord into electrical outlet.
	Front Panel may not be properly installed. Remove and reinstall the Front Panel to assure proper placement.
	Household circuit breaker / ground fault interrupter has tripped or blown a fuse. Reset circuit breaker / ground fault interrupter, or replace fuse. For assistance, contact a licensed electrician.
	Unit is damaged or in need of repair. Cease usage and unplug. Contact Consumer Service for assistance.
	Controls may be locked. If Lock symbol is illuminated, press and hold the Control Lock button for 3 seconds to turn Off.
<b>Airflow is weak or slow.</b>	Unit set to a low speed setting. Adjust to a higher speed setting.
	Debris build-up on filter. Check and replace filters.
	Airflow is blocked. Remove obstruction.



# Happy Parent Guarantee

Call Toll Free

800.234.0604

[www.vornadobaby.com](http://www.vornadobaby.com)

[support@vornadobaby.com](mailto:support@vornadobaby.com)

If you're not satisfied with this product, let us know. We'll go the extra mile to ensure you're a happy Vornadobaby parent!

Vornado Air LLC ("Vornado") warrants to the original consumer or purchaser this Vornadobaby® Purio Nursery HEPA Air Purifier ("Product") is free from defects in material or workmanship for a period of five (5) years from the date of purchase. If any such defect is discovered within the warranty period, Vornado, at its discretion, will repair or replace the Product at no cost.

## For warranty or repair service:

Call 1-800-234-0604 or email [support@vornadobaby.com](mailto:support@vornadobaby.com) to obtain a Return Authorization ("RA") form. Please have or include your Product's model number and serial number, as well as your name, address, city, state, zip code and phone number when contacting Vornado for warranty service.

## After receiving the RA form, ship your Product to:

Vornado Air LLC Attn: Warranty & Repair 415 East 13th Street Andover, KS 67002 For your convenience, please have your model number and serial number when contacting Vornado with service inquiries. To assure proper handling, packages must be clearly marked with the RA number. Packages not clearly marked with the RA number may be refused at the receiving dock. Please allow 1-2 weeks for repair and return of your Product after the Product is received.

Product registration available online at [www.vornadobaby.com](http://www.vornadobaby.com)

Repairs not covered by the warranty or outside the warranty period will require a fee to cover the cost of materials, labor, handling and shipping. This warranty does not apply to defects resulting from abuse of the Product, modification, alteration, repair or service of the Product by anyone other than Vornado, mishandling, improper maintenance, commercial use of the Product, damages which occur in shipment or are attributed to acts of God. REPAIR OR REPLACEMENT AS PROVIDED UNDER THIS WARRANTY IS THE EXCLUSIVE REMEDY OF THE CONSUMER. VORNADO SHALL NOT BE LIABLE FOR ANY INCIDENTAL OR CONSEQUENTIAL DAMAGES FOR BREACH OF ANY EXPRESS OR IMPLIED WARRANTY ON THIS PRODUCT. EXCEPT TO THE EXTENT PROHIBITED BY APPLICABLE LAW, ANY IMPLIED WARRANTY OF MERCHANTABILITY OR FITNESS FOR A PARTICULAR PURPOSE ON THIS PRODUCT IS LIMITED IN DURATION TO THE DURATION OF THIS WARRANTY. Some states do not allow the exclusion or limitation of incidental or consequential damages, or allow limitations on how long an implied warranty lasts, so the above limitations or exclusions may not apply to you. This warranty gives you specific legal rights, and you may have other rights that vary from state to state.



Designed, engineered and supported in Andover, KS

© 2021 Vornado Air LLC Andover, KS 67002 U.S. Patent Pending. Specifications subject to change without notice. Vornado® and Vornadobaby® are trademarks owned by Vornado Air LLC.



Speak your mind [vornadobaby.com/reviews](https://vornadobaby.com/reviews)

Vornado Air, LLC  
415 East 13th Street, Andover, Kansas 67002  
800.234.0604  
[vornadobaby.com](https://vornadobaby.com)  
[support@vornadobaby.com](mailto:support@vornadobaby.com)